



Cisco Aironet 12 dBi High Gain Omnidirectional Antenna (AIR-ANT24120)

Overview

This document outlines the specifications and description of the 12-dBi high gain omnidirectional antenna. This antenna operates in the 2400-2500 MHz band and is designed for use outdoors. The antenna is compatible with Cisco Aironet radio products utilizing a reverse-polarity TNC (RP-TNC) connector.

The following information is provided in this document:

- [Overview, page 1](#)
- [Technical Specifications, page 2](#)
- [System Requirements, page 3](#)
- [Installation Notes, page 3](#)
- [Safety Precautions, page 5](#)
- [Obtaining Documentation and Submitting a Service Request, page 6](#)



Technical Specifications

Antenna type	Vertical colinear array, Omnidirectional	
Operating frequency range	2400-2500 MHz	
Nominal input impedance	50 ohms	
Nominal VSWR	1.5:1	
Peak gain	12 dBi	
Polarization	Linear, vertical	
Dimensions	42 x 1.5 in (106 x 3.8 cm)	
Weight	3 lb (1.36 kg)	
Connector type	RP-TNC plug	
Coax type	RG-213	
Environment	Outdoor	
Operating temperature range	-40°F to 158°F (-40°C to 70°C)	
Wind rating	125 mph (201 kmh)	

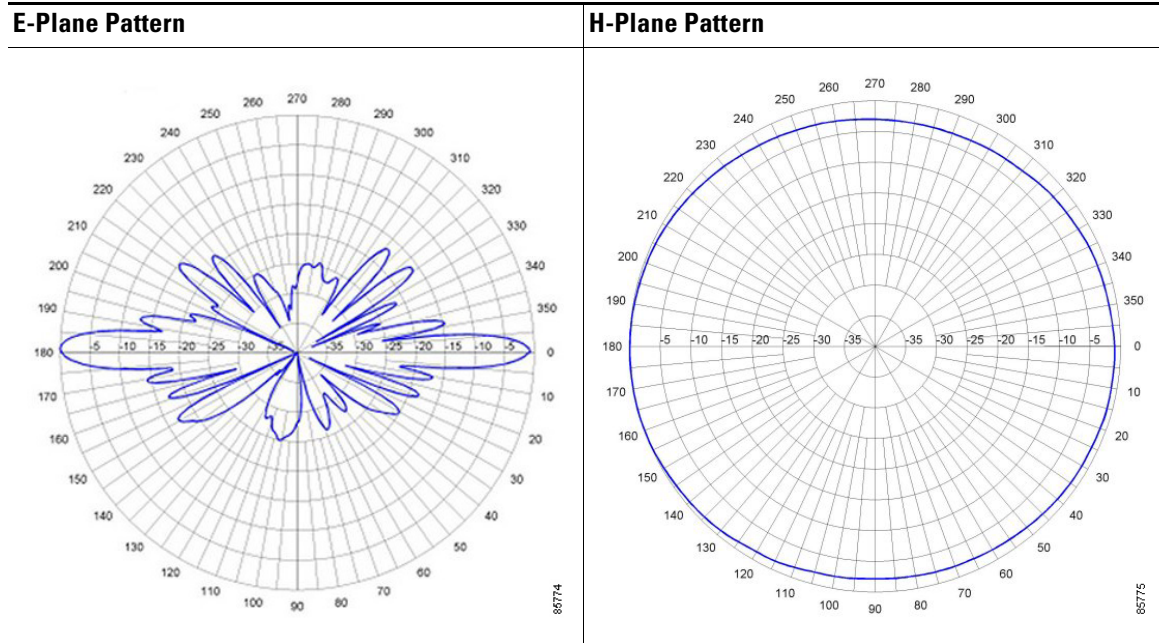

System Requirements

This antenna is designed for use with Cisco Aironet access points and bridges but can be used with any 2.4-GHz Cisco Aironet radio device that uses a reverse-polarity threaded naval connector (RP-TNC).

Installation Notes

Choosing a Mounting Location

The antenna is designed to create an omni-directional broadcast pattern. To achieve this pattern, the antenna should be mounted clear of any obstructions to the sides of the radiating element. If the mounting location is on the side of a building or tower, the antenna pattern will be blocked on the building or tower side.

Tools and Equipment Required

To install the antenna, you will need the following tools and equipment.

- A 7/16 in. (11 mm) open end or combination wrench
- A 1/2 in. (13 mm) open end or combination wrench

The following sections contain procedures for installing the antenna. Choose the procedure that applies to your situation. Use Figure 1 as a guide.

Mounting the Antenna

The antenna is provided with a mounting kit. This kit allows you to mount the antenna to masts up to three inches in diameter. The antenna is vertically polarized. Since the antenna has vertical gain, it is very important to mount the antenna in a vertical (not leaning) position for optimal performance.

Follow these steps to mount the antenna to a mast.

-
- Step 1** Position the sandcast bracket on the mast.
 - Step 2** Secure the sandcast bracket to the mast using two 5/16–18 U-bolts, split lock washers, and hex nuts.
 - Step 3** Use a 1/2 in. (13 mm) wrench to tighten each hex nut to full compression of the split lock washers.
 - Step 4** Slide the antenna in the sandcast bracket and align it so that the 1/4–20 hex bolts fit into the grooves on the antenna base.
 - Step 5** Use a 7/16 in. (11 mm) wrench to tighten the hex bolts until they secure the antenna to the sandcast bracket. Do not overtighten.
 - Step 6** Use a 7/16 in. (11 mm) wrench to tighten the 1/4–20 jam nuts. Do not overtighten.
 - Step 7** Connect the antenna's pigtail coaxial cable to the transmission line.
-



Note It is recommended that you install lightning-protection devices in your system, such as the Cisco Aironet Lightning Arrestor, part number AIR-ACC3354.

Figure 1 *Antenna Mount Assembly*

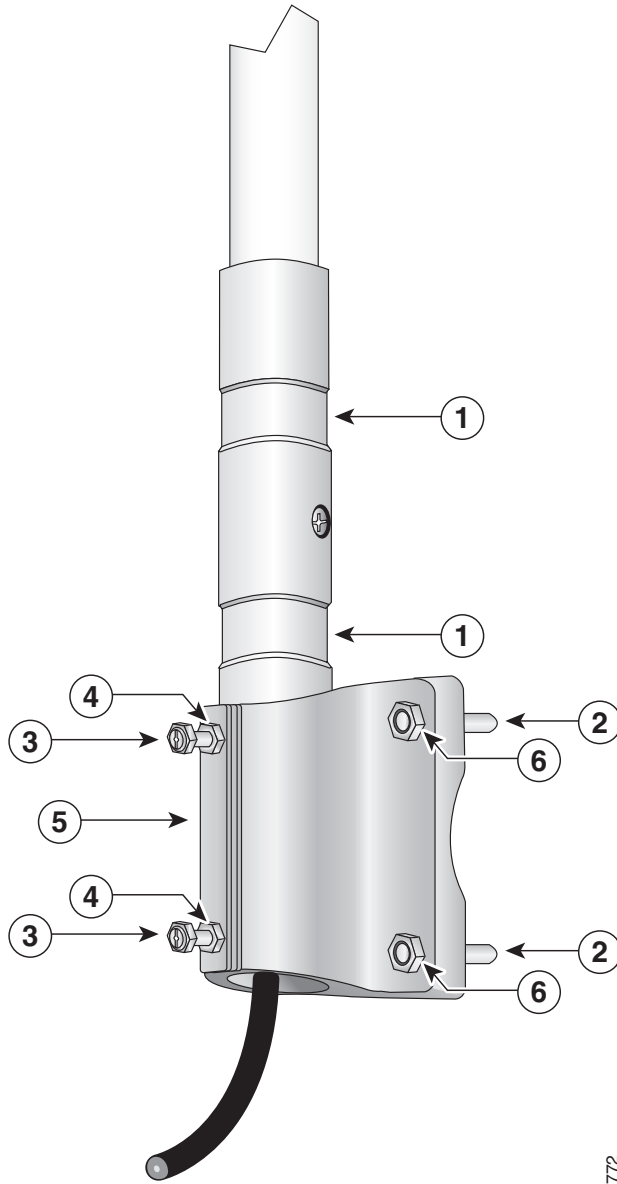

85772

1	Antenna grooves	4	Jam nuts
2	5/16 x 18 U-bolt	5	Sandcast bracket
3	1/4-20 hex bolts	6	5/16-18 hex nut

Suggested Cable

Cisco recommends a high-quality, low-loss 50-ohm cable for use with the antenna, such as those listed in Table 1.

Table 1 Specifications for Cisco Aironet Low-Loss Antenna Cable

Feature	AIR-CAB020LL-R	AIR-CAB050LL-R	AIR-CAB100ULL-R	AOR-CAB150ULL-R
Cable length	20 ft (6 m)	50 ft (15 m)	100 ft (30 m)	150 ft (46 m)
Transmission loss	1.3 dB	3.4 dB	4.4 dB	6.6 dB



Note

The higher the frequency, the higher the loss through the cable. Also, the longer the run, the higher the loss.

The antenna terminates with a special connector (reverse-TNC plug) after a short, 1-ft. cable. The mating connector to the antenna is an appropriate reverse-TNC jack connector. The connector on the opposite end varies according to the type of equipment used.

After the cable is attached to the antenna, make sure that the connections are sealed (if using outdoors) to prevent moisture and other weathering elements from affecting performance.



Note

The holes on the bottom of the antenna at the base (where the cable exits the antenna) should not be covered. These holes allow the antenna to vent any internal condensation.

Cisco recommends using a coax seal for outdoor connections. Silicon sealant or electrical tape are **not** recommended for sealing outdoor connections.

The final step is to attach the antenna to your wireless device.

Safety Precautions



Warning

Installation of this antenna near power lines is dangerous. For your safety, follow the installation directions.

Each year hundreds of people are killed or injured when attempting to install an antenna. In many of these cases, the victim was aware of the danger of electrocution, but did not take adequate steps to avoid the hazard.

For your safety, and to help you achieve a good installation, please read and follow these safety precautions. **They may save your life!**

1. If you are installing an antenna for the first time, for your own safety as well as others, seek professional assistance. Your Cisco sales representative can explain which mounting method to use for the size and type antenna you are about to install.
2. Select your installation site with safety, as well as performance in mind. Remember: electric power lines and phone lines look alike. For your safety, assume that any overhead line can kill you.

3. Call your electric power company. Tell them your plans and ask them to come look at your proposed installation. This is a small inconvenience considering your life is at stake.
4. Plan your installation carefully and completely before you begin. Successful raising of a mast or tower is largely a matter of coordination. Each person should be assigned to a specific task, and should know what to do and when to do it. One person should be in charge of the operation to issue instructions and watch for signs of trouble.
5. When installing your antenna, remember:
 - a. **Do not** use a metal ladder.
 - b. **Do not** work on a wet or windy day.
 - c. **Do** dress properly—shoes with rubber soles and heels, rubber gloves, long sleeved shirt or jacket.
6. If the assembly starts to drop, get away from it and let it fall. Remember, the antenna, mast, cable, and metal guy wires are all excellent conductors of electrical current. Even the slightest touch of any of these parts to a power line complete an electrical path through the antenna and the installer: **you!**
7. If any part of the antenna system should come in contact with a power line, **don't touch it or try to remove it yourself. Call your local power company.** They will remove it safely.

If an accident should occur with the power lines call for qualified emergency help immediately.

Obtaining Documentation and Submitting a Service Request

For information on obtaining documentation, submitting a service request, and gathering additional information, see the monthly *What's New in Cisco Product Documentation*, which also lists all new and revised Cisco technical documentation, at:

<http://www.cisco.com/en/US/docs/general/whatsnew/whatsnew.html>

Subscribe to the *What's New in Cisco Product Documentation* as a Really Simple Syndication (RSS) feed and set content to be delivered directly to your desktop using a reader application. The RSS feeds are a free service and Cisco currently supports RSS Version 2.0.

Cisco and the Cisco Logo are trademarks of Cisco Systems, Inc. and/or its affiliates in the U.S. and other countries. A listing of Cisco's trademarks can be found at www.cisco.com/go/trademarks. Third party trademarks mentioned are the property of their respective owners. The use of the word partner does not imply a partnership relationship between Cisco and any other company. (1005R)