



Cisco Aironet 14-dBi Patch Antenna (AIR-ANT5114P-N)

This document outlines the specifications for the Cisco Aironet 14-dBi Patch Antenna (AIR-ANT5114P-N) and provides instructions for mounting it. The antenna operates in the 4.9 to 5.8-GHz frequency range and is designed for use in both indoor and outdoor environments.

The following information is provided in this document.

- [Technical Specifications, page 2](#)
- [System Requirements, page 4](#)
- [Safety Precautions, page 4](#)
- [Installation Notes, page 5](#)
- [Installing the Antenna, page 6](#)
- [Obtaining Documentation and Submitting a Service Request, page 10](#)



Americas Headquarters:
Cisco Systems, Inc., 170 West Tasman Drive, San Jose, CA 95134-1706 USA

© 2007 Cisco Systems, Inc. All rights reserved.

Technical Specifications

Antenna type	2 x 2 Patch Array
Operating frequency range	4900 MHz - 5850 MHz
VSWR	4900 MHz - 5850 MHz
Gain	13 dBi @4900 MHz - 5470 MHz 14 dBi @5470 MHz - 5850 MHz
Polarization	Linear, Vertical
Front-to-back ratio	20 dB
Azimuth plane half-power beamwidth	29 degrees
Elevation plane half-power beamwidth	25 degrees
Length	4-1/8 in. (10.4 cm)
Width	4-1/8 in. (10.4 cm)
Height	1-3/8 in. (3.49 cm)
Cable length and type	Plenum Rated, UV Stable, Cold Temperature Capable
Connector	Female-N
Operating temperature	-22 to 158 F (-30 C to +70 C)

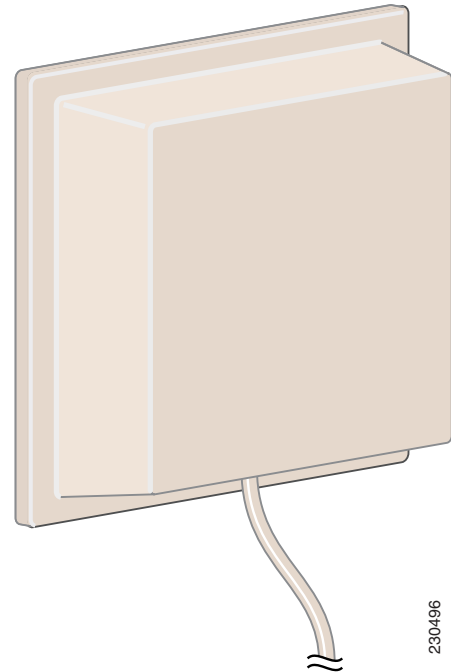

230496

Azimuth Radiation Pattern

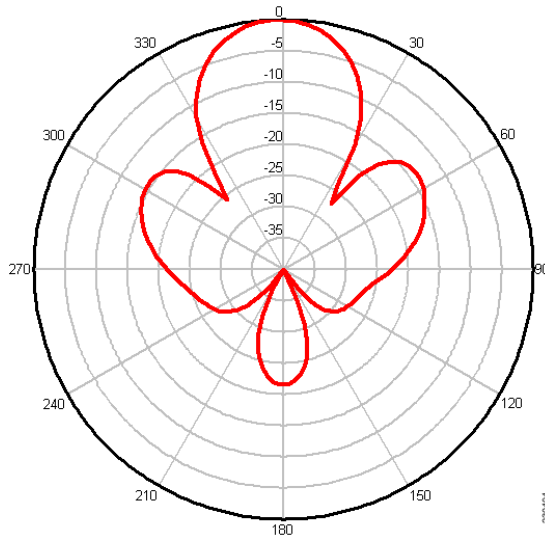

Elevation Radiation Pattern

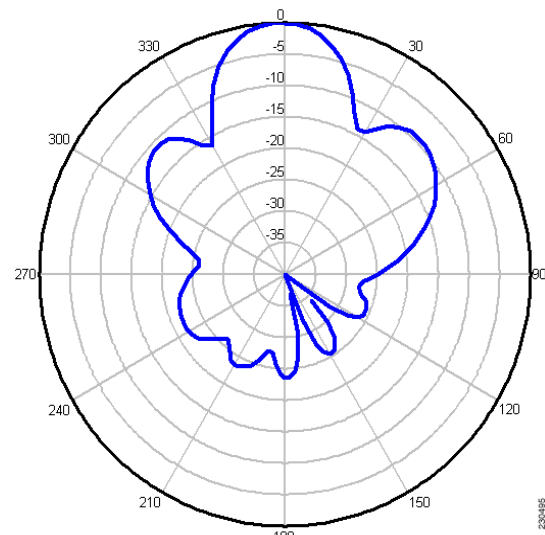

The following table indicates the minimum required attenuation between the access point radio and the antenna when using the lowest RF power setting. Using a higher RF power setting will require additional attenuation (for a given antenna).

The attenuation can be in the form of an attenuator, coax cable loss, or both. This attenuation is required for the system to meet the regulatory requirements of the indicated country. Failure to install the minimum amount of attenuation results in non-compliant operation. Table 1 shows the required attenuation.



Note X indicates that the antenna is not authorized to be used in that country.

Table 1 Required Attenuation in dB

	2.4 GHz Antennas (802.11 B /G)			5 GHz Antennas (802.11 A)		
	AIR-ANT2480V-N 2.4 GHz 8 dBi Omni	AIR-ANT2410Y-R 2.4 GHz 10 dBi Yagi	AIR-ANT2414S-R 2.4 GHz 14 dBi Sector	AIR-ANT58G10SSA-N 5 GHz 9.5 dBi Sector	AIR-ANT5114P-N 4.9–5.8 GHz 14 dBi Patch	AIR-ANT5117S-N 4.9–5.8 GHz 17 dBi Sector
Asia						
Australia	None	None	None	None	-1	-4
China	None	None	None	None	-1	-4
Hong Kong	None	None	None	None	-1	-4
India	None	None	None	X	X	X
Japan	None	X	X	X	X	X
Korea	X	X	X	X	X	X
New Zealand	None	None	None	None	-1	-4
Singapore	None	-1	-5	None	-1	-4
Taiwan	None	X	X	None	X	X
Thailand	None	-1	-5	X	X	X
EU						
Belgium	None	-1	-5	None	-2	-5
Denmark	None	-1	-5	None	-2	-5
Finland	None	-1	-5	None	-2	-5
France	None	-1	-5	None	-2	-5
Germany	None	-1	-5	None	-2	-5
Italy	None	-1	-5	None	-2	-5
Netherlands	None	-1	-5	None	-2	-5
Norway	None	-1	-5	None	-2	-5
Spain	None	-1	-5	None	-2	-5

Table 1 Required Attenuation in dB (continued)

	2.4 GHz Antennas (802.11 B /G)			5 GHz Antennas (802.11 A)		
	AIR-ANT2480V-N 2.4 GHz 8 dBi Omni	AIR-ANT2410Y-R 2.4 GHz 10 dBi Yagi	AIR-ANT2414S-R 2.4 GHz 14 dBi Sector	AIR-ANT58G10SSA-N 5 GHz 9.5 dBi Sector	AIR-ANT5114P-N 4.9–5.8 GHz 14 dBi Patch	AIR-ANT5117S-N 4.9–5.8 GHz 17 dBi Sector
Sweden	None	-1	-5	None	-2	-5
Switzerland	None	-1	-5	None	-2	-5
United Kingdom	None	-1	-5	None	-2	-5
North America						
United States	None	X	X	None	None	None
Canada	None	X	X	None	None	None
Mexico	None	None	None	None	-1	-4
South America						
Brazil	None	None	None	None	-1	-4

System Requirements

This antenna is designed for use with Cisco Aironet access points and bridges but can be used with any 5-GHz Cisco Aironet radio device that uses N-connectors.

Safety Precautions

Translated versions of the following safety warnings are provided in the *Safety Warnings for Cisco Aironet Antennas*, which is available at <http://www.cisco.com>.



Warning

Installation of this antenna near power lines is dangerous. For your safety, follow the installation directions.

Each year hundreds of people are killed or injured when attempting to install an antenna. In many of these cases, the victim was aware of the danger of electrocution but did not take adequate steps to avoid the hazard.

For your safety, and to help you achieve a good installation, please read and follow these safety precautions. **They may save your life!**

1. If you are installing an antenna for the first time, for your own safety as well as others, seek professional assistance. Your Cisco sales representative can explain which mounting method to use for the size and type antenna you are about to install.
2. Select your installation site with safety as well as performance in mind. Remember: electric power lines and phone lines look alike. For your safety, assume that any overhead line can kill you.

3. Call your electric power company. Tell them your plans and ask them to come look at your proposed installation. This is a small inconvenience considering your life is at stake.
4. Plan your installation carefully and completely before you begin. Successful raising of a mast or tower is largely a matter of coordination. Each person should be assigned a specific task, and should know what to do and when to do it. One person should be in charge of the operation to issue instructions and watch for signs of trouble.
5. When installing your antenna, remember:
 - a. **Do not** use a metal ladder.
 - b. **Do not** work on a wet or windy day.
 - c. **Do** dress properly—shoes with rubber soles and heels, rubber gloves, long sleeved shirt or jacket.
6. If the assembly starts to drop, get away from it and let it fall. Remember, the antenna, mast, cable, and metal guy wires are all excellent conductors of electrical current. Even the slightest touch of any of these parts to a power line completes an electrical path through the antenna and the installer: **You!**
7. If any part of the antenna system should come in contact with a power line, **don't touch it or try to remove it yourself. Call your local power company.** They will remove it safely.
8. If an accident occurs with the power lines, call for qualified emergency help immediately.

Installation Notes

Antennas transmit and receive radio signals which are susceptible to RF obstructions and common sources of interference that can reduce throughput and range of the device to which they are connected. Follow these guidelines to ensure the best possible performance:

- Install the antenna vertically and mount it as high as possible.
- Keep the antenna away from metal obstructions such as heating and air-conditioning ducts, large ceiling trusses, building superstructures, and major power cabling runs. If necessary, use a rigid conduit to lower the antenna away from these obstructions.
- The density of the materials used in a building's construction determines the number of walls the signal can pass through and still maintain adequate signal strength. Consider the following before choosing the location for your antenna:
 - Signals penetrate paper and vinyl walls with little change to signal strength.
 - Signals penetrate only one or two solid and pre-cast concrete walls without degrading signal strength.
 - Signals penetrate three or four concrete and wood block walls without degrading signal strength.
 - Signals penetrate five or six walls constructed of drywall or wood without degrading signal strength.
 - Signals will likely reflect off a thick metal wall and may not penetrate it at all.
 - Signals will likely reflect off a chain link fence or wire mesh spaced between 1 and 1 1/2 in. (2.5 and 3.8 cm). The fence acts as a harmonic reflector that blocks the signal.
- Install the antenna away from microwave ovens and 2-GHz cordless phones. These products can cause signal interference because they operate in the same frequency range as the device to which your antenna is connected.

Choosing a Mounting Location

The antenna is designed to create a directional broadcast pattern. To achieve this pattern, the antenna should be mounted clear of any obstructions to the sides of the radiating element. If the mounting location is on the side of a building or tower, the antenna pattern is degraded on the building or tower side.

Site Selection

Before attempting to install your antenna, determine where you can best place the antenna for safety and performance.

Follow these steps to determine a safe distance from wires, power lines, and trees.

Step 1 Measure the height of your antenna.

Step 2 Add the height to the length of your tower or mast and then double this total for the minimum recommended safe distance.



Caution

If you are unable to maintain this safe distance, stop and get professional help.

Generally, the higher an antenna is above the ground, the better it performs. Good practice involves installing your antenna about 5 to 10 ft (1.5 to 3 m) above the roof line and away from all power lines and obstructions. If possible, find a mounting place directly above your wireless device to ensure the lead-in cable can be as short as possible.

Installing the Antenna

You can install the antenna on any flat vertical surface or on a pole. Hardware for mounting the antenna on drywall is provided. If you intend to install your antenna on another surface, you must provide the appropriate hardware.



Note

Four mounting screws are provided to mount the antenna. To ensure a safe, reliable, and long-standing installation, you must use all four screws to mount the antenna.

Tools and Equipment Required

A mounting installation kit is included with the antenna and consists of the following hardware:

- Four #8 x ¾ in. screws and four #8 plastic wall anchors
- Wall mount plate
- Knuckle
- Two 1/4 in.-20 azimuth and elevation adjustment bolts and nuts with 1/4 in. flat washers and lock washers

- Two hose clamps

You need the following tools and equipment, which are not provided.

- A #2 Phillips screwdriver
- A 1/4" Flat-head screwdriver
- A drill
- A #29 0.136-in. (3.45 mm) drill bit for drywall installation; other surfaces may require a different size
- A pencil
- A small mallet or hammer

Mounting on a Vertical Surface

Follow these steps to mount your antenna on a vertical surface. This procedure describes mounting the antenna on a drywall surface. If you are mounting the antenna on any other type of surface, your procedure may vary slightly.

-
- Step 1** Determine the mounting location for the antenna.
- Step 2** Use the articulated mount base as a template to mark the locations of the four mounting holes.
- Step 3** Use a drill and a 3/16 in. drill bit to drill four holes at the locations you marked in Step 2.
- Step 4** Start a plastic wall anchor into each hole.
- Step 5** Use a mallet or small hammer to seat the wall anchors into the wall.
- Step 6** Align the articulated mount base's mounting holes with the anchors.

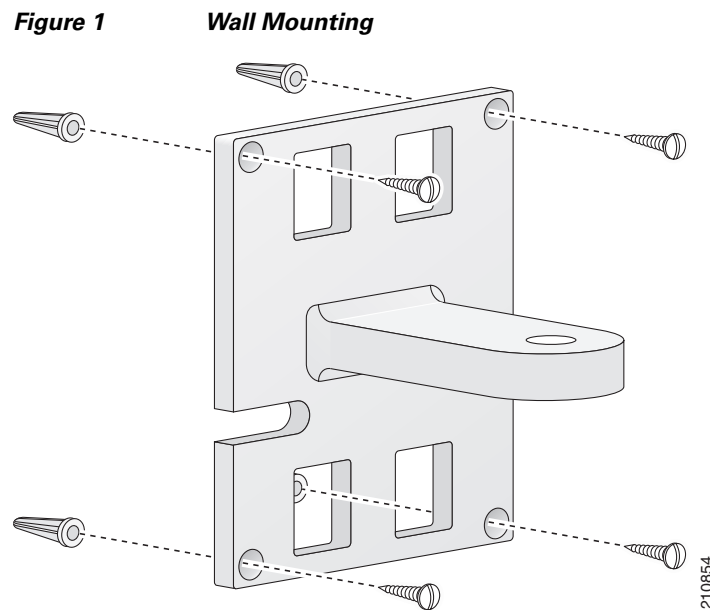

- Step 7** Start a 8-18 self-tapping screw into each antenna mounting hole.
- Step 8** Use a Phillips screwdriver to secure the articulated mount base to the wall. Do not overtighten.

Step 9 Complete the assembly of the other parts as described beginning in step 3 of the following section.

Installing the Articulated Mount

The antenna is mounted on an articulated mounting device as shown in [Figure 2](#). The articulated mount is used to provide a way to adjust the antenna elevation and azimuth through a limited range.

Figure 2 Articulated Mount Details

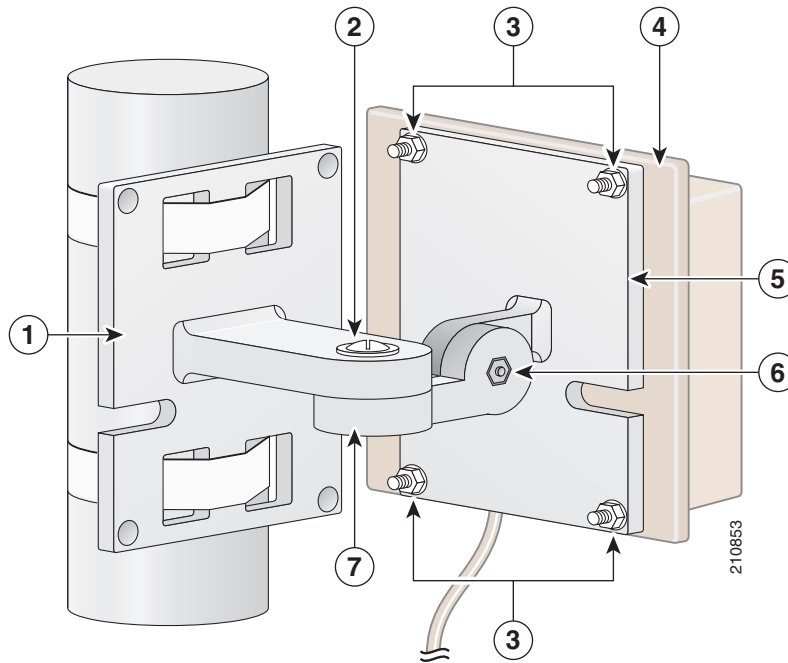

1	Articulated mount base	5	Antenna mounting plate
2	Azimuth adjustment bolt	6	Elevation adjustment bolt
3	Stud nuts	7	Knuckle
4	Antenna		

[Figure 2](#) shows the articulated mount installed on a pole. You can also install it on any suitable flat surface, as mentioned in the previous section.

Follow these steps to install the articulated mount on an upright pole:

- Step 1** Place hose clamps around the pole and the articulated mount base as shown.
- Step 2** Position the mounting plate on the pole in the direction the antenna should face and tighten the hose clamp with a screwdriver.
- Step 3** Use the azimuth adjustment bolt, nut, and washers to install the knuckle assembly on the articulated mount base. Tighten the screw finger tight.

- Step 4** Use the elevation adjustment bolt to attach the antenna mounting plate and antenna to the knuckle assembly. Tighten the screw finger tight.
- Step 5** Use the azimuth and elevation adjustments to fine tune the antenna's azimuth and elevation.
- Step 6** When the antenna is properly adjusted, use a flat-head screwdriver to tighten the azimuth and elevation adjustment screws. Do not overtighten.
- Step 7** Route the antenna cable to the wireless device.



Note Cisco recommends grounding the antenna. See the [“Grounding the Antenna”](#) section on page 9 for details.



Caution

If you install additional lengths of antenna cable, be sure to install a suitable strain relief. The antenna may be damaged if you do not eliminate the extra weight of the cable. The antenna is not designed to support the weight of a cable longer than the installed cable.

Suggested Cable

Cisco recommends a high-quality, low-loss cable for use with the antenna.



Note

Coaxial cable loses efficiency as the frequency increases, resulting in signal loss. Because cable length also determines the amount of signal loss, the cable should be kept as short as possible (the longer the run, the greater the loss).

The antenna terminates with an N-connector after a short, 1-ft (30.5-cm) cable. The mating connector to the antenna is an appropriate N-connector jack. The connector on the opposite end will vary according to the type of equipment used.

After the cable is attached to the antenna, make sure that the connections are sealed (if outdoors) to prevent moisture and other weathering elements from affecting performance. Cisco recommends using a coax seal (such as CoaxSeal) for outdoor connections. Silicon sealant or electrical tape are **not** recommended for sealing outdoor connections.

Grounding the Antenna

Follow these steps to ground the antenna in accordance with national electrical code instructions.

- Step 1** Use No. 10 AWG copper or No. 8 or larger copper-clad steel or bronze wire as ground wires for both mast and lead-in. Securely clamp the wire to the bottom of the mast.
- Step 2** Secure the lead-in wire to a static discharge unit (lightning arrestor, Cisco Aironet AIR-ACC245LA-R or equivalent).
- Step 3** Secure the mast ground wire to the building with stand-off insulators spaced from 4 ft (1.2 m) to 8 ft (2.4 m) apart.
- Step 4** Mount the antenna discharge unit as closely as possible to where the lead-in wire enters the building.

Step 5 Drill a hole in the building's wall as closely as possible to the equipment to which you will connect the lead-in cable.



Caution There may be wires in the wall. Make sure your drilling location is clear of any obstructions or other hazards.

Step 6 Pull the cable through the hole and form a drip loop close to where it enters the building.

Step 7 Thoroughly waterproof the lead-in area.

Step 8 Connect the lead-in cable to the equipment.

Obtaining Documentation and Submitting a Service Request

For information on obtaining documentation, submitting a service request, and gathering additional information, see the monthly *What's New in Cisco Product Documentation*, which also lists all new and revised Cisco technical documentation, at:

<http://www.cisco.com/en/US/docs/general/whatsnew/whatsnew.html>

Subscribe to the *What's New in Cisco Product Documentation* as a Really Simple Syndication (RSS) feed and set content to be delivered directly to your desktop using a reader application. The RSS feeds are a free service and Cisco currently supports RSS Version 2.0.

Cisco and the Cisco Logo are trademarks of Cisco Systems, Inc. and/or its affiliates in the U.S. and other countries. A listing of Cisco's trademarks can be found at www.cisco.com/go/trademarks. Third party trademarks mentioned are the property of their respective owners. The use of the word partner does not imply a partnership relationship between Cisco and any other company. (1005R)